

Engineered to be Load and Go SIMPLICITY is what it is all about

Have your "about town vehicle" with you wherever you go with your **Cloud Nine Carrier®**

The Transport Systems **Cloud Nine Carrier®** is a quality product that when used correctly provides a safe, effective means of transporting your favorite get about town vehicle behind your Motor Coach allowing you to back up while maintaining complete control.

The **Cloud Nine Carrier®** air ride suspension provides a very efficient dampening system, resulting in a smoother ride for your towed vehicle.

Your vehicle actually floats on a cushion of air, eliminating much of the shock from rough road, bumps, pot holes and otherwise less than smooth traveling.

Placing a standard trailer hitch ball on the **Cloud Nine Carrier®** will classify the Carrier to be rated as a Class V Hitch.

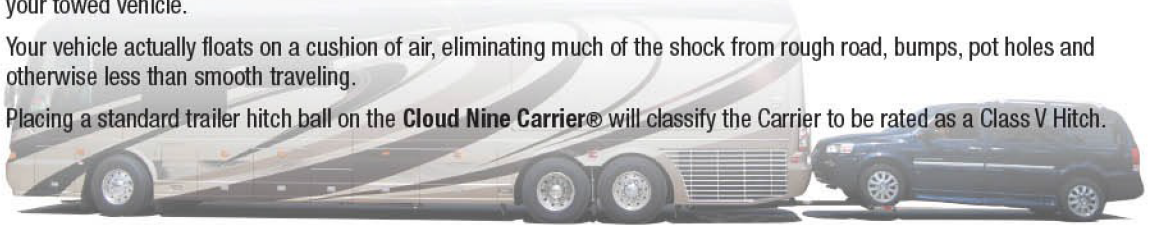

SPECIFICATIONS:

Pneumatic and Hydraulic Controlled System
Total Installed System weight of 1075 lbs

MODELS:

Platform Model 72
Wheels Outside to Outside 72" Max
Wheels Inside to Inside 50.5" Min

Platform Model 88
Wheels Outside to Outside 88" Max
Wheels Inside to Inside 66.5" Min

Stationary Frame Model 40
Distance from Wheel Centerline to front of vehicle 40" Max

Stationary Frame Model 50
Distance from Wheel Centerline to front of vehicle 50" Max

RWD TOWED VEHICLE SPECIFICATIONS:

Minimum towing vehicle weight: 20,000 lbs.
Maximum front axle weight of towed vehicle is 3,000 lbs for vehicle and contents.
Maximum total weight of towed vehicle varies by vehicle type and loading.
Typical RWD vehicle is approximately 6,000 lbs.

FWD TOWED VEHICLE SPECIFICATIONS:

Minimum towing vehicle weight: 20,000 lbs.
Maximum front axle weight of towed vehicle is 3,000 lbs for vehicle and contents.
Maximum total weight of towed vehicle varies by vehicle type and loading.
Typical FWD vehicle is approximately 5,000 lbs

TOWING PROCEDURE:

Follow all OEM, Distributor and Dealer Towing Procedures

SYSTEM REQUIREMENTS:

Chassis rear access
Access to 60 psi air pressure
12V or 24V power available
20 Amps Available

MODEL: 7240

Platform Model: 72
Stationary Frame Model: 40

MODEL: 7250

Platform Model: 72
Stationary Frame Model: 50

MODEL: 8840

Platform Model: 88
Stationary Frame Model: 40

MODEL: 8850

Platform Model: 88
Stationary Frame Model: 50

DELIVERY: TO BE DETERMINED AT TIME OF ORDER

Prices Include Basic Installation.
SOME RESTRICTIONS APPLY

Using Your Cloud Nine Carrier® Is A Very Easy 7 Step Process.

1. Extend And Lower The Cloud Nine Platform
2. Extend The Wheel Ramps
3. Place Vehicle On The Platform
4. Secure Vehicle With Wheel Straps
5. Attach And Secure Safety Chains
6. Plug In Ancillary Lighting
7. Raise The Cloud Nine Platform To The Correct Height

You are Now Ready to go
With No Worrying About Ingress or Egress,
Just Go and Enjoy Your Trip!



US PATENT
6,692,218 B2
7,448,839 B2

AUTHORIZED
INSTALLATION:
OEM
Distributor
Dealer

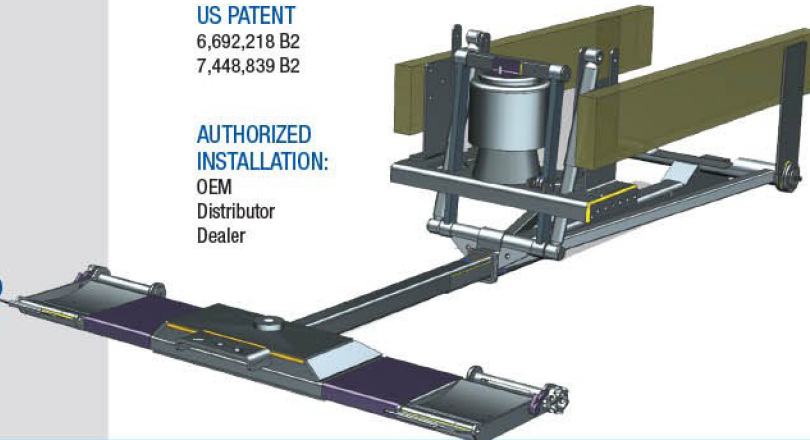

SERVICES AVAILABLE

Technical Support
Installation and Setup
Maintenance
Application Support
Hardware Support
Guaranteed Warranty